

!ATTENTION: READ BEFORE ASSEMBLING/OPERATING!

ASSEMBLY INSTRUCTIONS FOR THE MULTICHAIR 6000Tilt Series

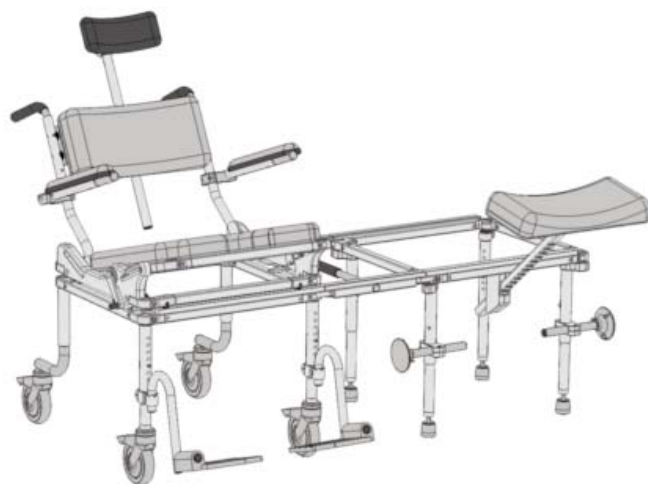

multichair 6000Tilt



multichair 6200Tilt



multichair 6000Tilt P1



multichair 6000Tilt P2

!ATTENTION: READ BEFORE ASSEMBLING/OPERATING!

ASSEMBLY INSTRUCTIONS

!ATTENTION: PLEASE READ!

Please see LIMITED WARRANTY of these instructions. If the warranty is not acceptable, contact Nuprodx, Inc. for information about returning the chair for a refund (Restocking fees and shipping charges will be applied). This chair is designed and intended for indoor shower and bathroom use. It is not designed for outdoor use and will void the warranty if used in this fashion. If thresholds, shower curbs or barriers are encountered that exceed ½" in height, the area in question should be brought within the code for disabled accessibility.

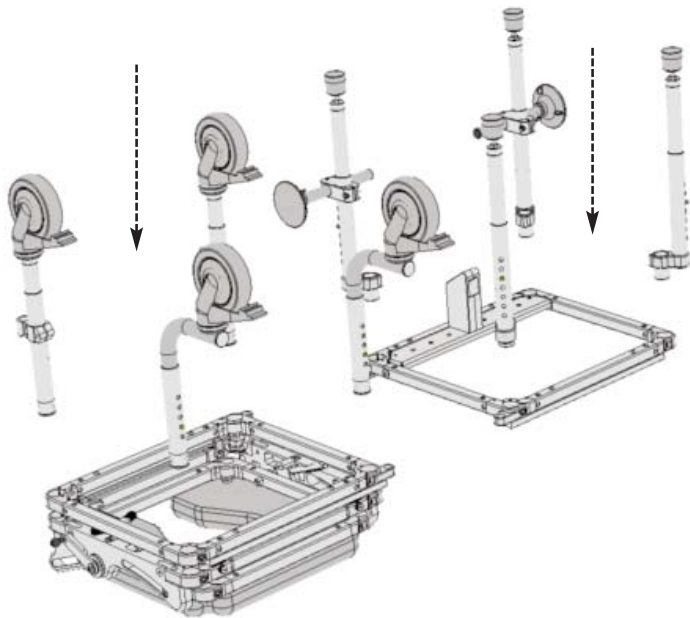

Figure 1

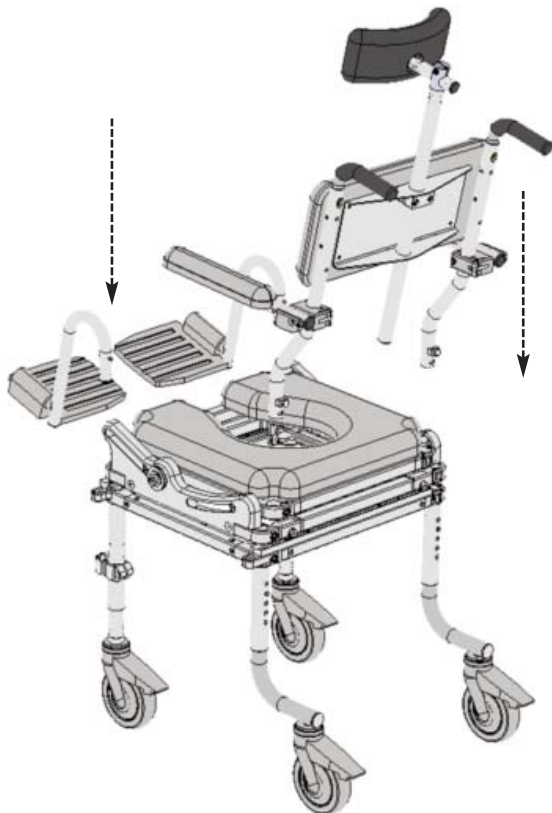

Figure 2

A The multiCHAIR 6000Tilt, 6200Tilt, 6000Tilt P1, and 6000Tilt P2 are composed of three sections: the **roll-in section** with (2) straight legs & 5" casters, (2) bent legs & 5" casters, the **connector bridge section**, and the **tub section** which has non-pinned offset legs and adjusting feet. The chair is shipped standard with the tub section positioned on the user's left side. Unpack all parts from the shipping carton.

B Remove all tape and/or packing from the chair. Keep shipping materials for future use. Note the location of padding materials and sheet-plastic which protects parts of your chair.

C Position the frames upside down and install the legs (Refer to Figure 1)

NOTE!

If you need to position the chair so the tub is on the user's right side, refer to the Additional Assembly Instructions on Page 3.

D Position the **roll-in section** rear bent legs so that they points out at a 90-degree angle. Make sure that the legs slide "home" into the socket of the seat frame. Use the included yellow T-handle Allen wrench to securely tighten the bolts located at the corners of the frame.

SAFETY PRECAUTION!

If any of the legs are not fitted correctly into the socket of the seat frame or are not securely tightened there is an extreme risk of the legs dislodging completely from the chair. This could cause serious injury or even death!

E The **tub section** legs do not have an indexing pin and can be rotated to best fit into the bath tub or shower stall. . Leg height adjustment is performed by pressing in the brass button on each leg. Fine tune height adjustment is performed by rotating the threaded feet at the bottom of the legs. There is a jam nut on each threaded leg bottom that can be tightened in place with a small Crescent wrench. The side suction cup assemblies are to secure the unit inside the tub. The suction faces of the cups should be parallel with the side tub walls. Then extended them out to create a tight fit within the tub. The yellow T-handle wrench is needed to make the adjustments.

F Turn the chair right side up and install the backrest assembly. Slide the two backposts into the back of the seat frame and tighten the two socket head cap screws using yellow T-handle Allen wrench (Refer to Figure 2).

G The footrests drop into the footrest brackets

H The calf support assembly is simply slide into the mounting block (Refer to figure 3), and be adjusted by sliding it within the mounting block than then pushing it down to engage one of the bottom slots on the square tube.

I Place the **connector bridge** into the matching holes on both the roll-in section and tub section (Refer to Figure 3).

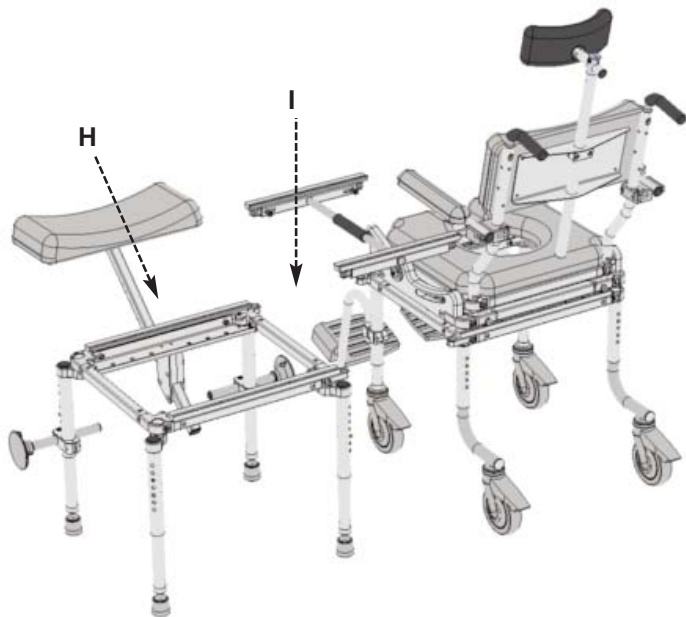

Figure 3

SAFETY PRECAUTION!

Both backrest posts must be completely engaged with the seat frame and securely tightened. If they are not fitted correctly, there is a risk of the posts dislodging from the seat frame. This could cause serious injury or even death!

SAFETY PRECAUTION!

The connector bridge must be fully seated into the corresponding holes of both the roll-in section and tub section. If this is not done correctly, the seat frame could dislodge itself from the chair when transferring from the roll-in section to the tub section.

SAFETY PRECAUTION!

The swing-away footrests should be installed into the footrest clamps after the user has been transferred into the chair. Putting an extreme amount of weight on the swing-away footrests or using them as an assistive device when transferring can cause the entire chair to tip forward, resulting in serious injury or even death!

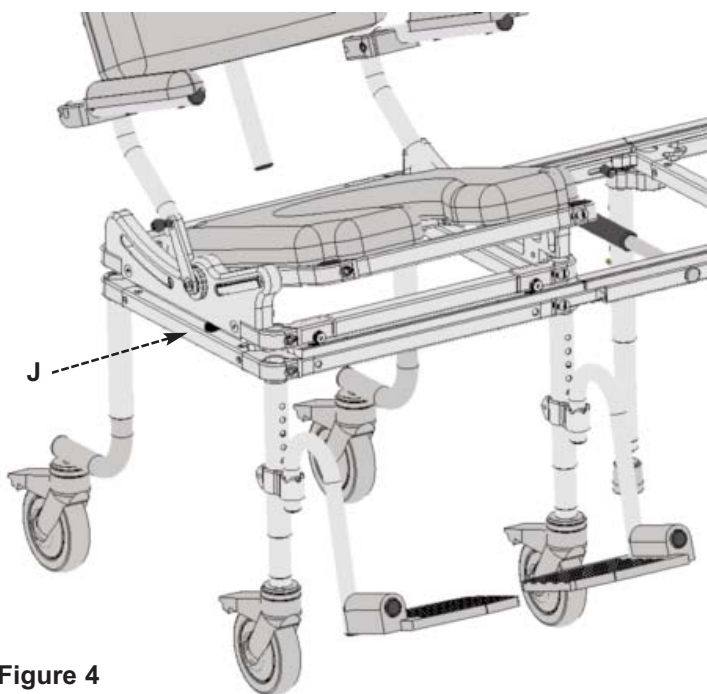

Figure 4

J The shuttle frame is released from the roll-in base by pulling back on the underside release lever and simultaneously sliding the shuttle towards the tub section base (Refer to Figure 4).

K The tilt mechanism is operated by pulling the spring loaded crank lever outwards and rotating the handle. Once the tilt angle is reached, we recommend either having the unit at its highest/largest tilt angle or flat, slowly release the spring loaded lever and it will automatically lock itself its pin into one of the indexing holes on the indexing disk (Refer to Figure 4)

L Index the handle by first positioning the seat in the horizontal position. The end of the crank handle should be approximately over the flat head socket bolt on the frame.

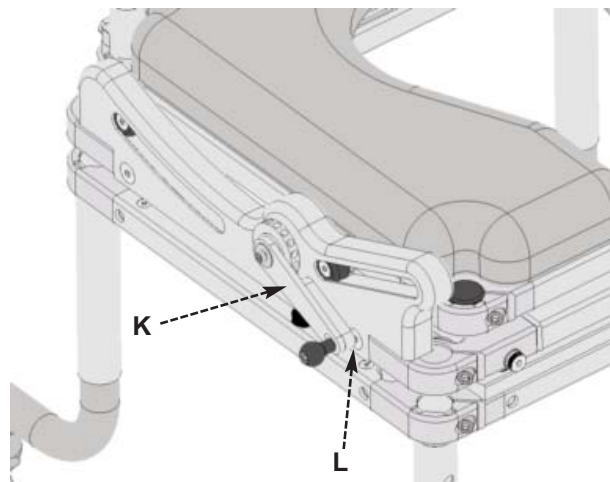

Figure 5

ADDITIONAL ASSEMBLY INSTRUCTIONS

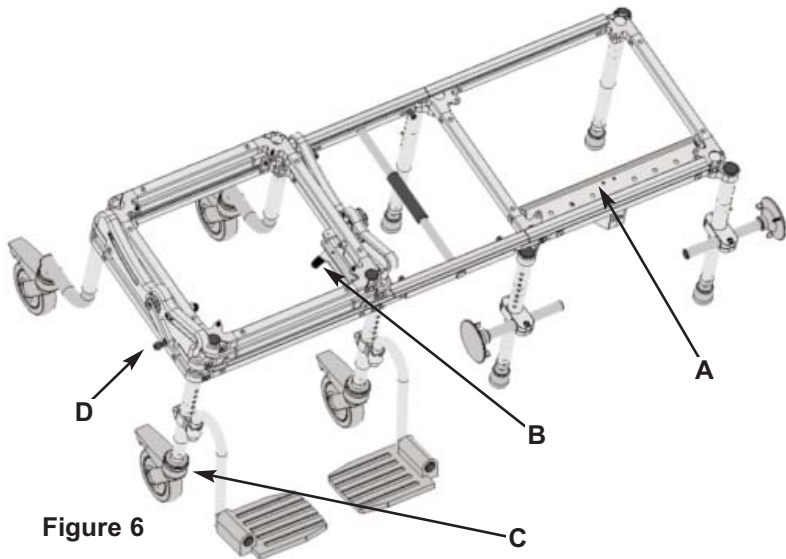

Figure 6

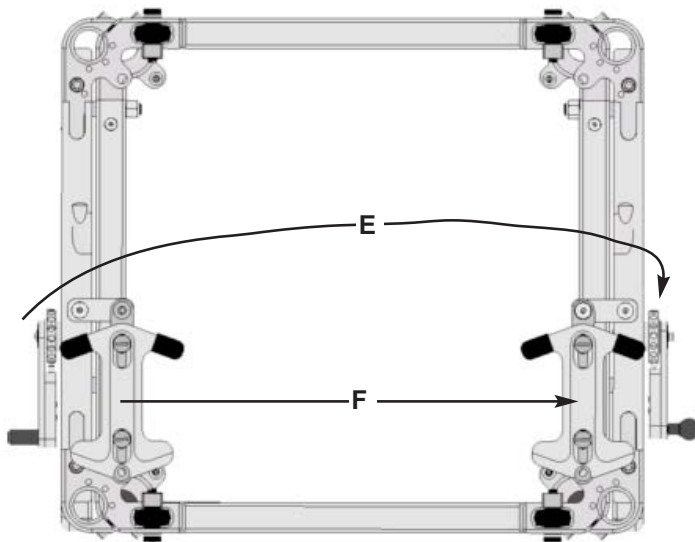

Figure 7

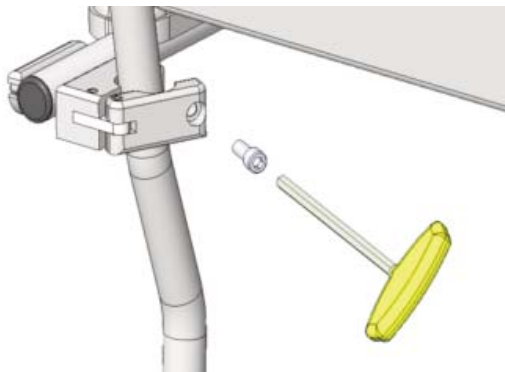

Figure 8

Reconfigure the multiCHAIR 6000Tilt, 6200Tilt, 6000Tilt P1, and 6000Tilt P2 with the Tub Section on the user's left side (Refer to Figures 6 and 7) The roll-in section and tub section frames are identical. To change slide direction do the following:

A Unbolt the sheet metal calf support plate using a large Phillip head screw driver and a small Crescent wrench and then reinstall it on the other frame.

B Move the latch stops as shown using the 5/32" Allen wrench that is provided with the slider

C Move the complete leg assemblies and the side suction cups from one frame to the other.

D Relocated the tilt system crank handle from one side of the shuttle frame to the other side

E Adjustments to the "Tilt Assembly" (Refer to Figure 5 on page 2 and Figure 7 this page) need to be made as follows: Remove the "crank handle" by removing the socket screw with an 1/8" Allen wrench. Remove the cap from the opposite side of the frame, again using an 1/8" Allen wrench, and install it on this side. Reinstall the crank handle on the opposite side of the frame. NOTE: position the seat in the horizontal position and the crank handle should be approximately covering the flat head socket bolt on the frame.

F Move the slider latch to the opposite side of the tilt assembly:

- 1) Remove the 1/4-20 Flat Head Socket Screw with the 5/32 Allen wrench that is provided with the slider.
- 2) The second 1/4-20 Flat Head Socket Screw is bolted to a nylon insert lock nut. Therefore a small crescent wrench or a 7/16" open end can be used to hold the nut while turning the screw.
- 3) Position the latch on the opposite side of the frame and reinstall.

Cantilever Arms: If desired, the cantilever arms can be removed from the backrest assembly for storage during traveling. This can be accomplished by unscrewing the socket head cap screws that attach the arms to the backrest posts using the 5/32" Allen wrench. Then remove the arm assemblies from the posts and re-insert the socket head cap screws into the arm assemblies, so they are not lost. To re-install the cantilever arms, simply follow the steps above in reverse (Refer to Figure 8).

NOTE!

Release Latch Assembly: Do not attempt to unscrew the inner slotted screws. Doing so can cause the entire latch assembly to come apart, rendering it useless (There is no tool provided for this operation) .

OPERATING INSTRUCTIONS

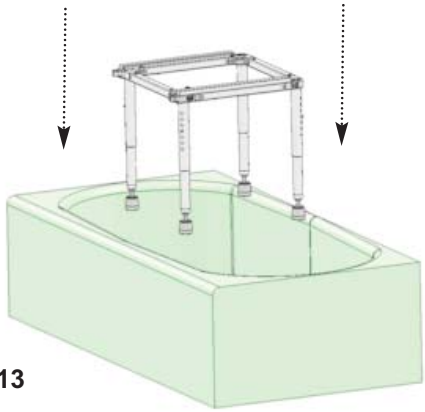

Figure 13

A Ensure all fasteners (bolts/washers) are securely tightened and all chair parts have been assembled correctly (Refer back to Assembly Instructions if needed. Contact Nuprodx, Inc. if unsure of anything).

B Place the assembled tub section of the slider into the desired position of the bath tub (Refer to Figure 13).

C Position the assembled roll-in section of the slider next to the outside wall of the bath tub (Refer to Figure 14).

D Adjust the height of the tub section to match the height of the roll-in section by either adjusting the four inner legs (tub section) and/or the adjustable crutch tips (tub section) - Refer to Figure 15.

E Insert the connector bridge into the four eyelet holes (Two located on the roll-in section and two located on the tub section) - Refer to Figure 16. Switch the four shoulder screws to the lock position on the connector bridge (Refer to Figure 17).

F Release the latch mechanism on the roll-in section and slide the slider seat assembly onto the tub section, making sure the latch engages fully and locks in place. If the roll-in section and tub section are not level in height or out of alignment, the slider seat assembly will not function correctly and safely. To ensure the safety of the user, make adjustments to both sections as needed and retry Step F (Refer to Figure 18).

G Remove the connector bridge to test the stability of the tub section. Also, ensure that the slider seat frame is locked into place and will not remove during use. Once this is complete, replace the connector bridge and slide the slider seat frame back to the roll-in section. The connector bridge can then be removed and the chair is ready for use.

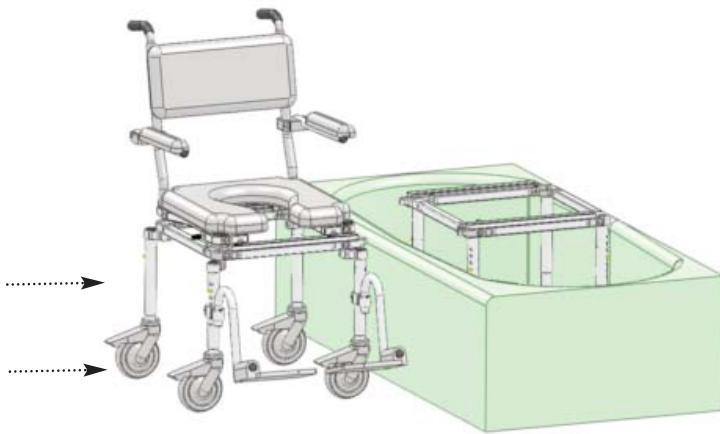

Figure 14

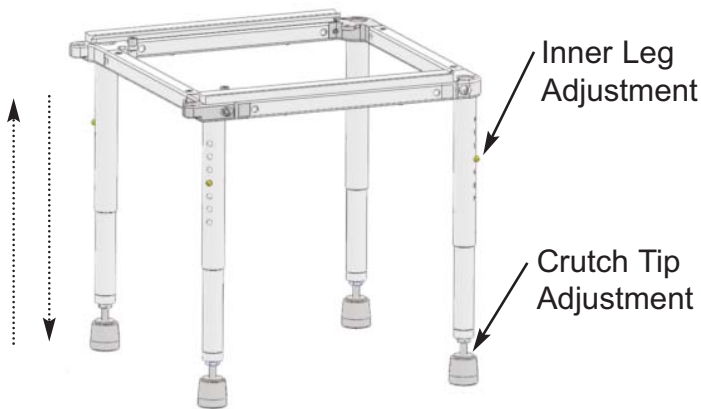

Figure 15



Figure 17

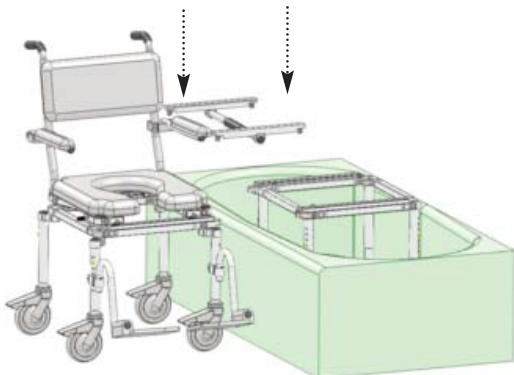

Figure 16

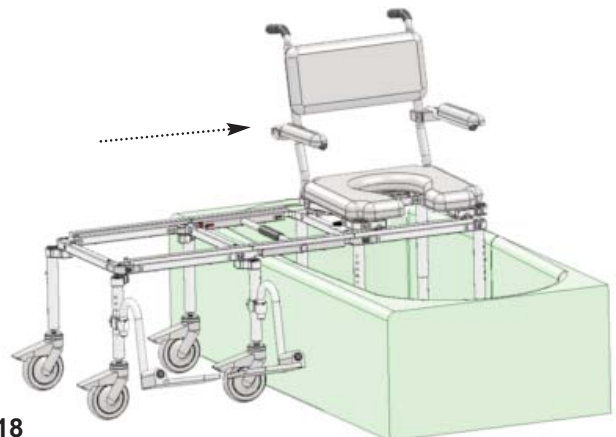
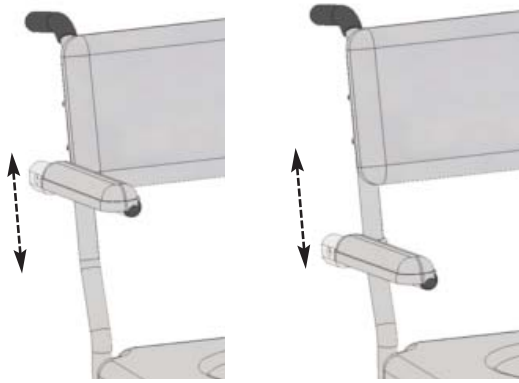

Figure 18



D Cantilever Arms: The cantilever arms can be adjusted to the desired height by completing the following steps: Loosen the socket head cap screws on the arm clamps, raise/lower the arms accordingly, then re-tighten the socket head cap screws (Refer to Figure 19). For safety purposes, the cantilever arms lock in the down position. To switch the arms to the up position, simply push the arms toward the back of the chair (releasing the locking mechanism) and lift up (Refer to Figure 20).

E Footrest Assemblies: Footrest clamps are installed on the front legs at the factory. Slide the footrest into the clamp. Loosen the pinch bolt on the footrest clamp and slide up/down as required by the user's leg length (Refer to Figure 21).

Figure 19

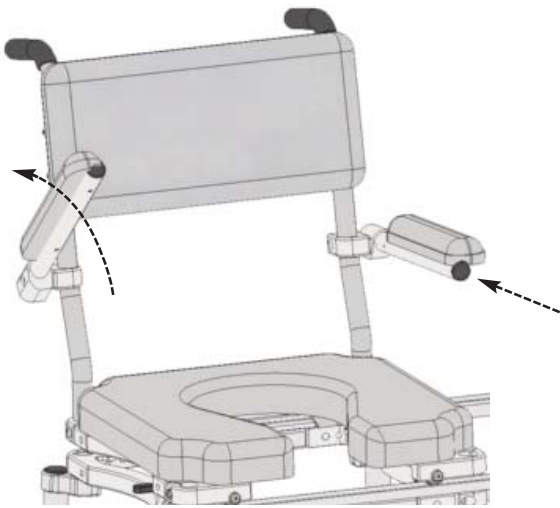

Figure 20

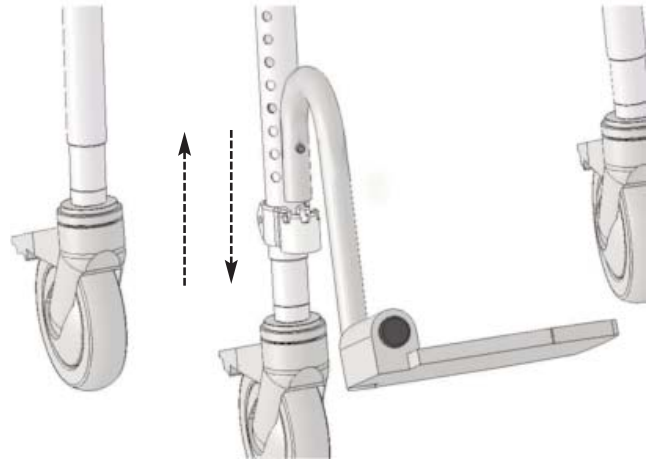

Figure 21

ADDITIONAL SAFETY PRECAUTIONS

!ATTENTION: PLEASE READ!

WARNING! Failure to account for the aforementioned and the following safety precautions can result in serious injury to the user or even death!

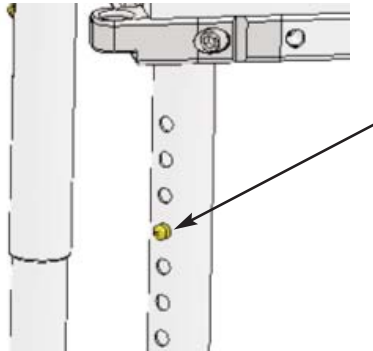

Figure 22

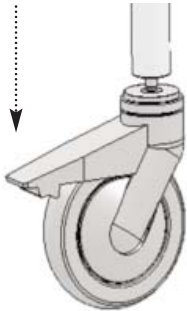

Figure 23

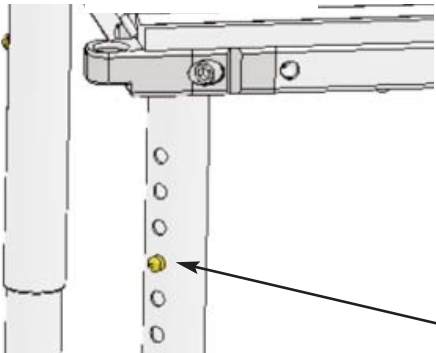

Figure 24

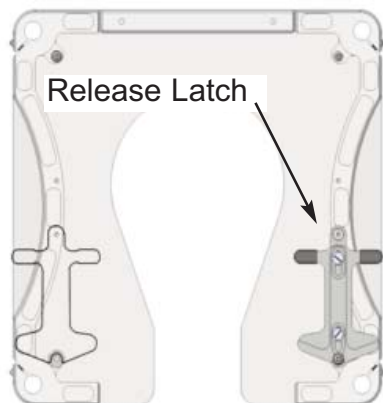

Figure 25

A Leg Height Adjustment: When making height adjustments to any of the legs, make sure that the brass buttons are fully engaged into the outer legs. If pushed too hard the button could become stuck inside the inner leg (Contact NuprodX, Inc. if this occurs). Leg height adjustment should only be made before transferring the user into the chair (Refer to Figure 22).

B Caster Wheels: When transferring into the chair, out of the chair and sliding the user from the roll-in section into the tub section, all four castor wheels should be securely locked in place. Failure to do so could cause the chair to become unstable (Refer to Figure 23).

C Fasteners: Over time the screws and washers on the chair may become loose. It is very important that these are checked and securely tightened before each use. Failure to do so could cause a part to dislodge from the chair (Refer to Figure 24).

D Release Latch: Verify that the release latch is fully engaged on the slider seat before removing the connector bridge (Refer to Figure 25).

E Leveling: The roll-in and tub sections must both be level and equal in height. To further adjust the height on the tub section legs, rotate the crutch tip feet clockwise or counterclockwise (Refer to Figure 26).

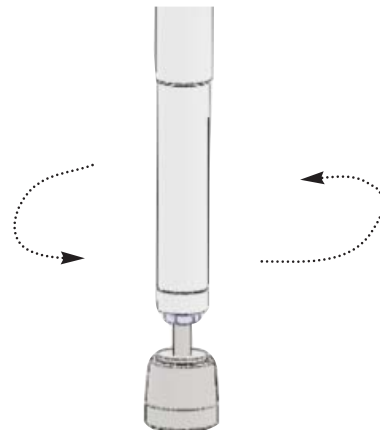

Figure 26

LIMITED WARRANTY

A WARRANTY ACTIVATION Please read this warranty before operating or using your multiCHAIR. To activate the warranty on your multiCHAIR register it online (www.nuprodx.com/form-registration/index.htm) or by phone (855-220-5171). By operating or using the chair, you agree to the terms of this warranty.

B WARRANTY: Nuprodx, Inc. warrants this product against defects in material and workmanship as follows: There is a *10-Day conditional money-back warranty*. During this time period, the customer is permitted to try out the multiCHAIR, fully-clothed, keeping the chair in "like new" condition (NOTE: "Like new" condition, in terms of the multiCHAIR, is defined by Nuprodx, Inc. as no visible wear/usage/water marks for the multiCHAIR to be accepted and refunds issued when returned to Nuprodx, Inc.). If the customer decides that the multiCHAIR will not work for them, before the 10-Day period has passed and with the authorization of Nuprodx, the chair can be returned for a full refund minus a *10% restocking charge* (NOTE: The customer is responsible for both in-bound and out-bound freight). After the initial 10-Day period has passed, there is a *two-year limited warranty* for all parts of the chair, with the exception of the seat and back cushions (NOTE: Because of the fragile nature of the foam, there is no warranty for the cushions). The warranty does not cover normal "wear and tear" from everyday use of the product and custom parts/custom cushions are also excluded from the warranty and cannot be returned for a refund under any circumstances. Please see section E WARRANTY LIMITATION AND EXCLUSIONS for more info on warranty exclusions.

C The warranty period begins on the date you receive the chair. For warranty service, please contact Nuprodx, Inc. no later than one month following the applicable warranty term. The chair will be repaired or replaced at the discretion of Nuprodx, Inc. with no charges to you for parts and labor, provided you have proof of purchase and of purchase date.

D DISCLAIMER: Except for the above warranty, and the acknowledgement by Nuprodx, Inc. that the chair, as manufactured by it, is fit for the general purpose for which most persons acquire a chair of its kind, Nuprodx, Inc. provides that you accept the chair as is, without warranties, either express or implied. Nuprodx, Inc. makes no warranty of fitness for your particular purpose and no warranty of merchantability beyond that already stated. No warranties extend beyond the duration of the express warranty stated above.

E WARRANTY LIMITATIONS AND EXCLUSIONS: The only obligation of Nuprodx, Inc. is to provide the purchaser with free repair and replacement as described above. This exclusive warranty remedy will not have failed as long as Nuprodx, Inc. is willing and able to repair or replace as described, but if this remedy should be held to have failed, the only remaining warranty obligation of Nuprodx, Inc. shall be to refund the acts beyond the control of Nuprodx, Inc. The warranty does not cover normal "wear and tear" from everyday use of the product. Standard seat/back cushions/custom parts/custom cushions are not covered under the warranty.

F This warranty gives you specific legal rights, and you may have other rights that may vary from state to state.

G This warranty does not apply to problems arising from normal wear, improper operation, improper maintenance, improper storage or similar disclaimer of implied warranties, and some do not allow limitations on how long an implied warranty may last. Some do not allow exclusion or limitation of incidental or consequential damages. So the above limitations or exclusions may not apply to you.

H RETURN INSTRUCTIONS In the event that you need to return the Nuprodx multiCHAIR, please follow the instructions below:

- 1) Review the information contained in your warranty to see if this applies to you
- 2) Obtain a Return Authorization # from Nuprodx, Inc. (855-220-5171)
- 3) Re-package the entire chair and its contents in the original packaging and ship to the following address:

Nuprodx, Inc. / Attn: RMA# xxxx
161 S. Vasco Rd., Suite G
Livermore, CA 94551
925-292-0714



889 Hayes St., Sonoma, CA 95476
(707) 934-8266, (707) 934-8269 fax, (855) 220-5171 toll free, info@nuprodx.com